

SQUARE PROP - Type I-SWL 200kN

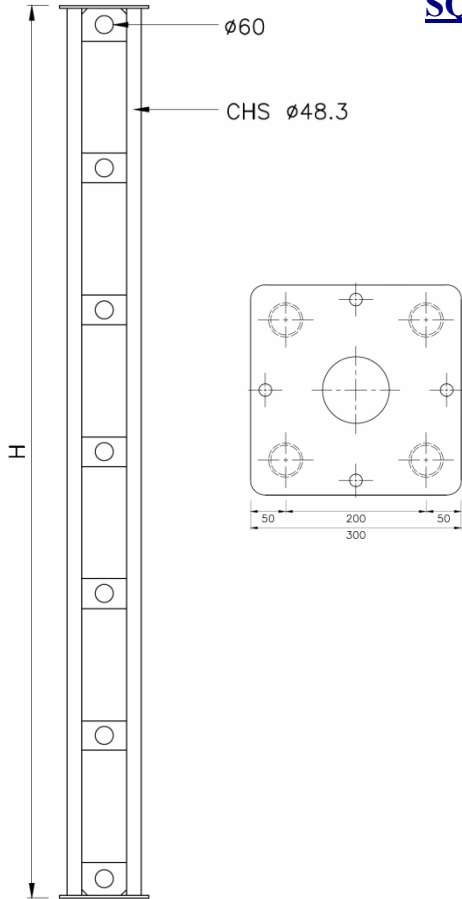

AVAILABLE SIZE

FSP050	500	22.3kg
FSP075	750	26.7kg
FSP100	1000	30.0kg
FSP125	1250	34.5kg
FSP150	1500	37.5kg
FSP200	2000	44.5kg
FSP225	2250	50.0kg
FSP250	2500	52.5kg
FSP300	3000	60.0kg

SECTION PROPERTIES -TYPE I

Cross Sectional Area	1390mm ²
Elastic Sectional Modulus Z	141210mm ³
Second Moment of Area I	1430500mm ⁴
Radius of Gyration r	101.3mm

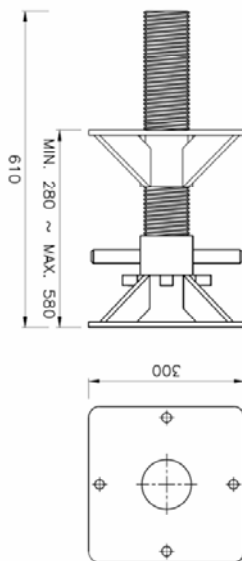

Base Jack

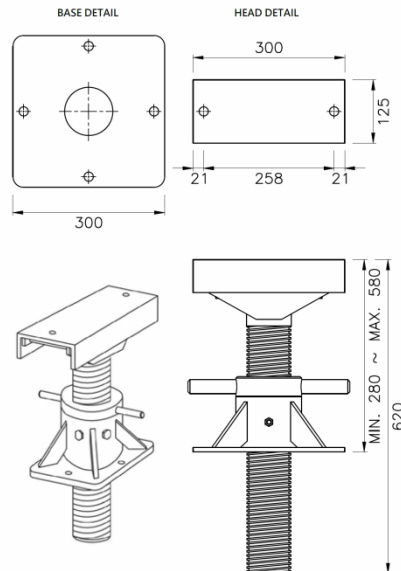

Fork Head Jack

SQUARE PROP- TYPE I

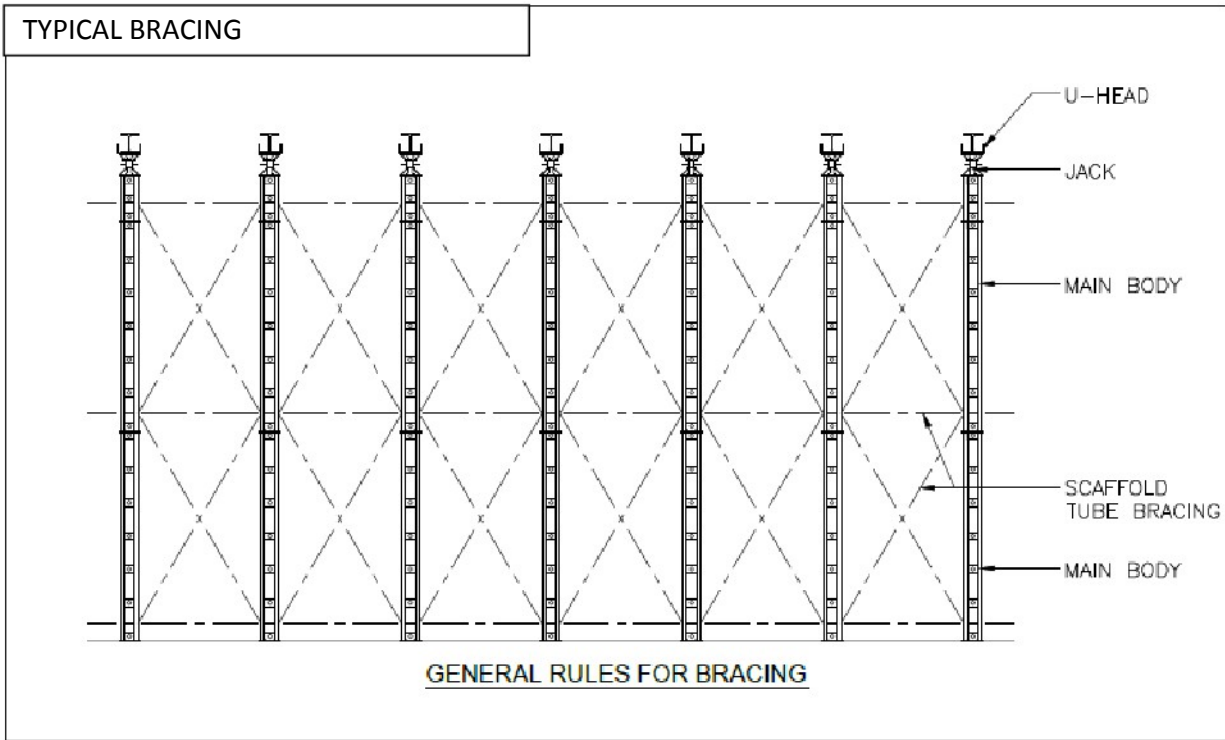

A FSP2000	1pc
B FSP3000	1pc
C FSP2000	2 Pcs
D FSP3000 + Base Jack	1pc

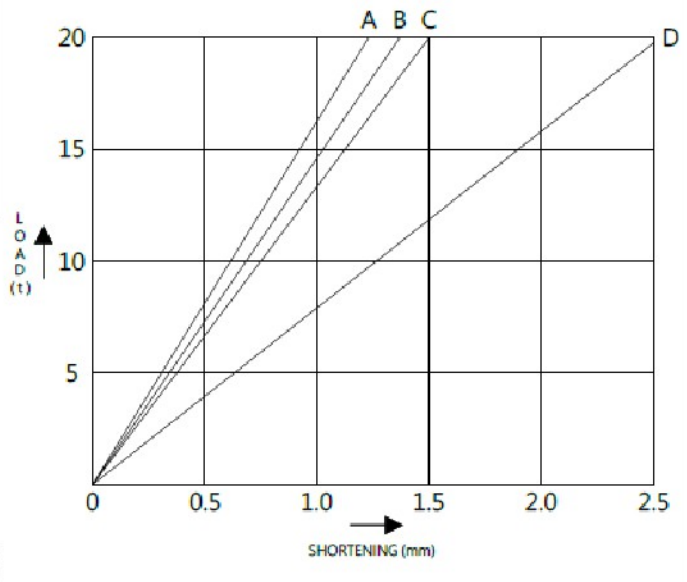
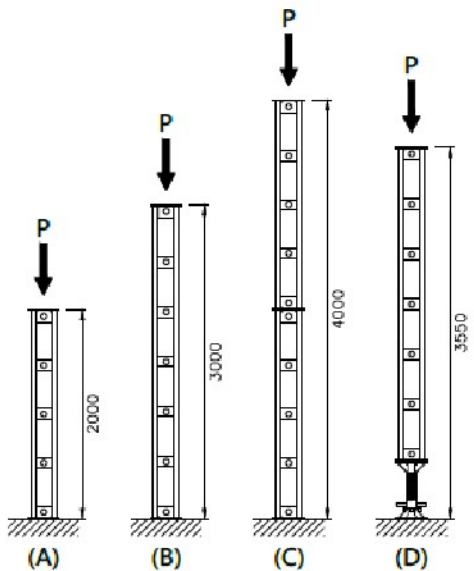

MAX DESIGN SAFE WORKING LOAD 200KN
WITH FOS=2